

SMEC

PL 1600G

GANG CNC TURNING CENTER



SMEC
SMEC CO.,LTD.

SMEC Co., Ltd.
157-10, Goldenroot-ro, Juchon-myeon,
Gimhae-si, Gyeongsangnam-do, Korea
Tel +82 55 340 4800
Fax +82 55 340 4740



www.esmec.com



https://www.youtube.com/c/smecmachinetools

SMEC
Smart One,
Global One

© SMEC 2020.02-NO.1

SMEC
SMEC CO.,LTD.

◆ Design and specifications subject to change without notice.

- 1988 - Started as Samsung Heavy Industries Machine Tools Business
- 1989 - Horizontal and vertical machining center technology partnership with OKK Japan
- 1991 - Turning center and vertical machining center technology partnership with Mori Seiki
- 1996 - 5-sided processing center technology partnership with Toshiba
- 1999 - Spun out from Samsung Aerospace Industries and established SMEC Co., Ltd

SMEC

Company

Engineering

Machine Tools

Samsung

PL 1600G



Minimum Maintenance Cost, Wide Machining Range

One Bed Casting Structure with High Rigidity

- Heavy duty cutting and Excellent vibration dampening made possible with 60 degree slant type.
- 2 way(Right, Rear) Chip Conveyor Available
- Available for Factory Automation
- Increased Repeatability
- Stable Traverse with LM Guide
- Large Diameter Ball Screw X- ϕ 32, Z- ϕ 36 applied



PL 1600G

High Accuracy and High Rigidity Spindle

- High precision angular ball bearings in the front of the spindle, High precision cylindrical roller bearings in the rear
- Spindle Structure with High Accuracy and High Rigidity
- Maintain Stability even during intermittent, heavy duty cutting.

Gang Type Tool Post

- Maximum Productivity by maximizing Chip to Chip
- Easy Chip Disposal with 60 degree slant type
- Increased efficiency for work and tooling

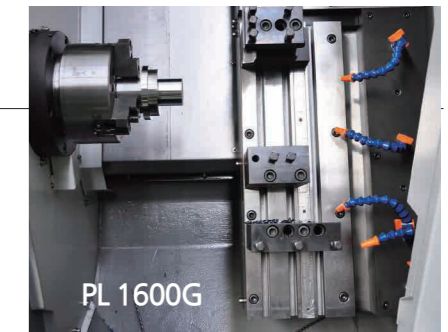

PL 1600G



Centralized Control Panel

Centralized Control Panel is designed for workers to minimize unnecessary movement and demonstrate excellent control performance for worker's convenience.

High Accuracy Double Anchored Ball Screws

- Minimizing thermal expansion.
- Increased machining accuracy
- Stabilized Repeatability



Spindle Power & Torque Diagram

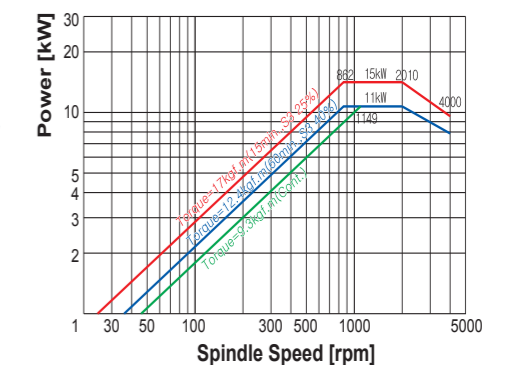

Work Range

Unit : mm

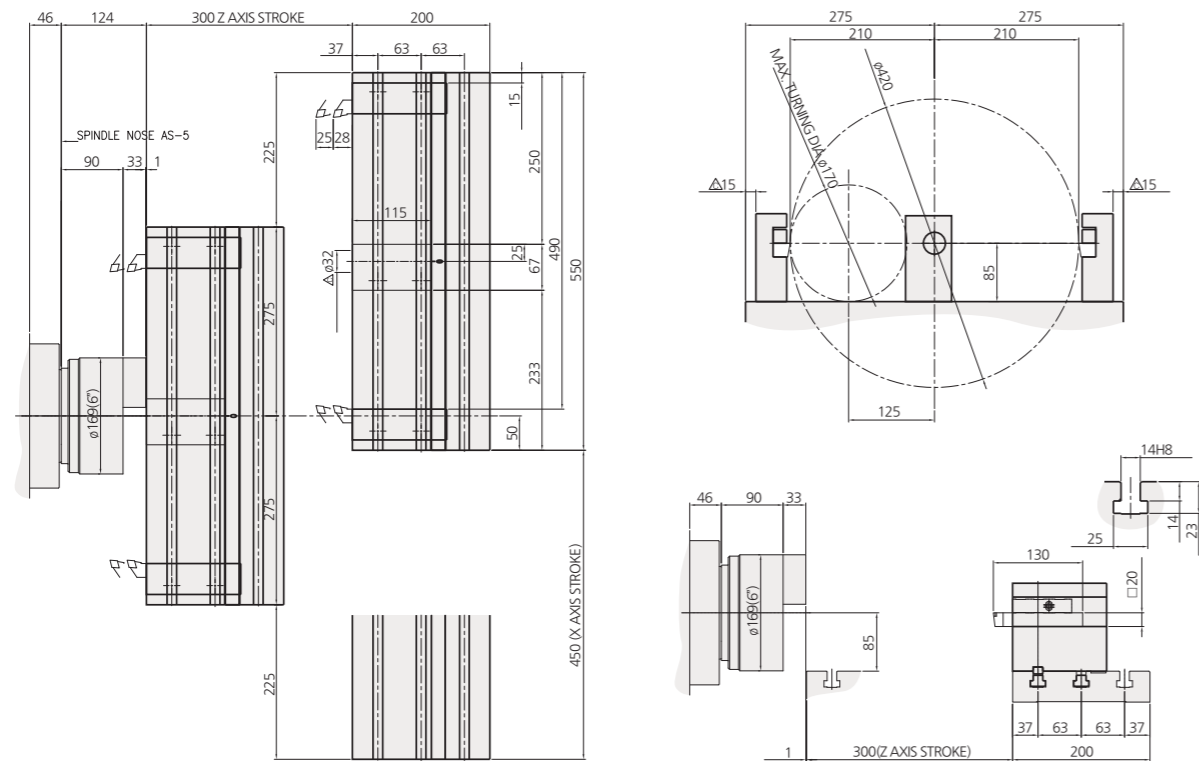

Machine Dimensions

Unit : mm

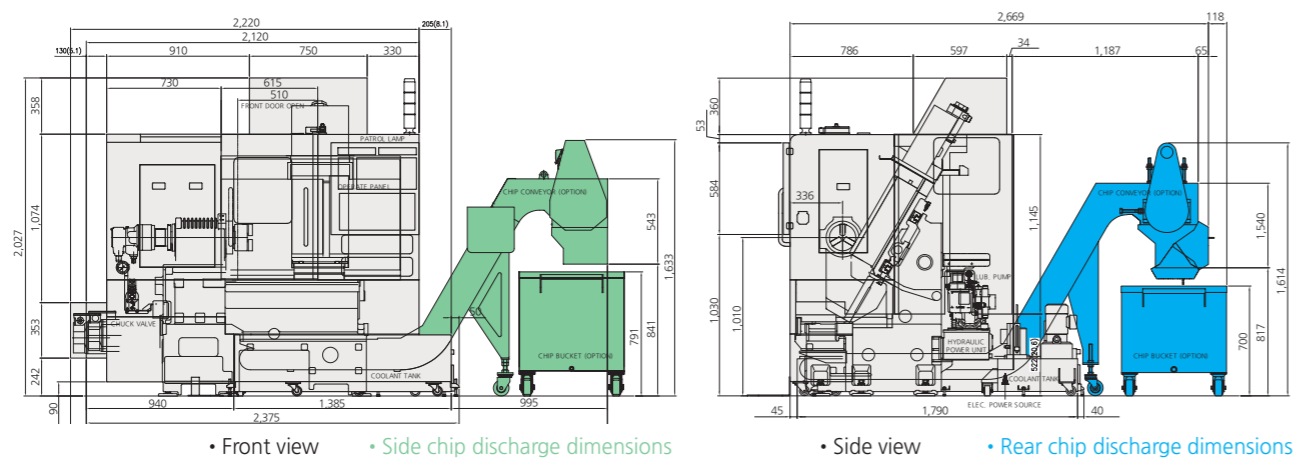

Tooling System

Unit : mm

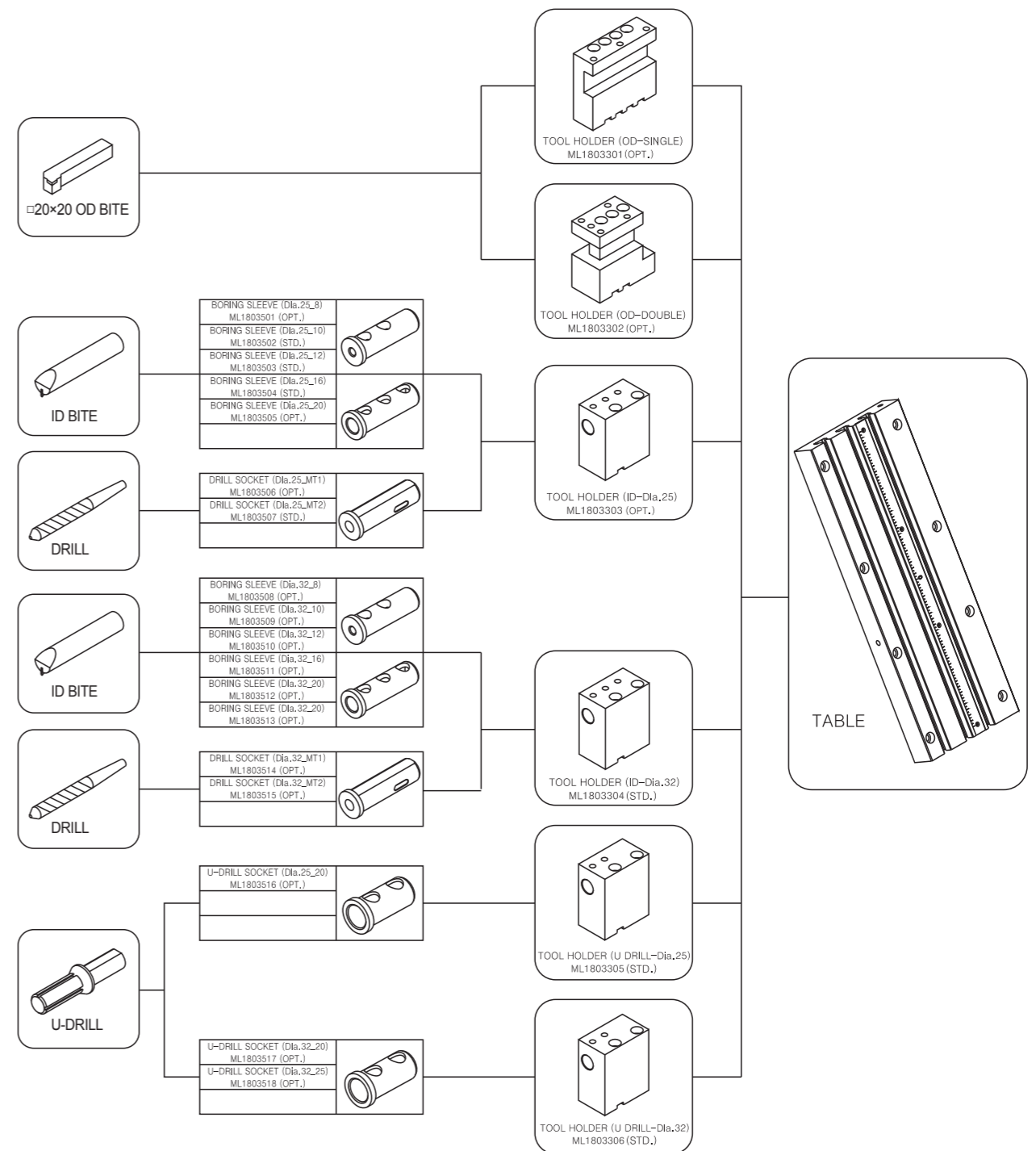

Machine Specification

DESCRIPTION			PL 1600G	
			A type	B type
Chuck	Chuck size	inch	6"	8"
Capacity	Swing over bed	mm	540	540
	Swing over cross slide	mm	170	170
	Max. turning diameter	mm	170	170
	Max. milling diameter	mm	-	-
	Max. machining length	mm	300	270
Spindle	Spindle speed	rpm	6,000	4,500
	Spindle nose	ASA	A2-5	A2-6
	Draw tube ID	mm	52	52
	Spindle bore diameter	mm	61	61
	Spindle motor (Cont./Max)	kW	11/15	11/15
Travels	X-axis travel	mm	450	450
	Z-axis travel	mm	300	270
	X-axis Rapid traverse rate	m/min	30	30
	Z-axis Rapid traverse rate	m/min	36	36
Turret	Number of tool stations	ea	3[6]	3[6]
	Turning tool shank size	mm	20	20
	Boring bar diameter	mm	32	32
	Turret index time(next station swivel time)	sec	-	-
Tailstock	Quill diameter	mm	-	-
	Quill stroke	mm	-	-
	Spindle taper	MT	-	-
Machine	Size (with Side Chip conveyor) LxWxH	mm	2,475(3,486) × 1,697 × 2,027	
	Size (with Rear Chip conveyor) LxWxH	mm	2,156× 2,149(2,941) × 2,027	
	weight	kg	3,000	3,200
	Coolant tank capacity	Liter	100	100
ELECTRIC POWER SUPPLY		kVA/V	28/220	28/220
CONTROLLER			FANUC	

※Design and specifications are subject to change without notice.

Standard Accessories

- 6" hollow 3 jaws chuck (A Type)
- 8" hollow 3 jaws chuck (B Type)
- Chuck clamp confirmation
- Chuck clamp foot switch
- Chuck pressure switch
- Coolant system
- Door interlock
- Full splash guard with coolant tank
- Jaw (soft 3set, hard 1set)
- Leveling unit
- Manual/Part list (1set)
- Patrol lamp (3colors)
- Safety precaution name plate
- Spindle orientation
- Tool box
- Tool holders
- Work light (LED lamp)

Optional Accessories

- Air blower
- Air conditioners (electric cabinet)
- Air gun
- Auto door
- Auto shutter (top)
- Bar Feeder Interface
- Chip bucket
- Chip conveyor (side, rear)
- Coolant blower
- Coolant chiller
- Coolant gun
- Coolant level switch
- Counter (total, multi, tool, work)
- Oil mist collector
- Oil skimmer
- Part catcher
- Robot interface
- Special chuck
- Steady rest
- Transformer

NC Specification (FANUC Series)

Item	Specification	Fanuc Series
Controlled axis	Controlled Axes	XY,(B)
	Max. simultaneously controlled axis	3
	Least command increment	0.001mm / 0.0001"
Operation functions	Pulse handle feed	X1, X10, X100
	Feedrate per minute	G98
	Feedrate per revolution	G99
Interpolation functions	Linear interpolation	G01
	Circular interpolation	G02, G03
	Dwell	G04
	Cylindrical interpolation	G70.1
	Reference position return	G28
	Reference position return check	G27
Feed function	Rapid traverse rate override	F0, 25%, 50%, 100%
	Feedrate override	0~150%
Spindle function	Spindle orientation	○
	Rigid tapping	○
Tool functions	Tool number command	T4-Digt / T2-Digt
	Tool nose radius compensation	G40 ~ G42
	Tool offset pairs	64
	Tool geometry/wear offset	GEOMETRY & WEAR DATA
	Tool life management	○
	Tool path graphic display	○
Program input	Automatic tool offset	×
	Absolute/incremental programming	○
	Multiple repetitive cycle	G70 ~ G76
	Canned cycles	G90, G92, G94
	Inch/metric conversion	G20 / G21
	Program restart	○
	Retraction for rigid tapping	○
	Max. programmable dimension	±99999.999mm/±9999.9999"
	M function M3 digit	M3 digit
	Custom macro	○
	Canned cycle for drilling	○
	Direct drawing dimension programming	○
	Programmable data input	G10
	Optional block skip	○
	Workpiece coordinate system	G52 ~ G59
Number of registerable programs	400EA	
Setting and display	Alarm&Operation Display	ALARM & OPERATION DISPLAY
	Run hour and parts count display	RUNNING TIME & PART NO. DISPLAY
	Display spindle & servo overload	SPINDLE & SERVO LOAD DISPLAY
	Self-diagnosis function	○
	Extended part program editing	COPY,MOVE, CHANGE OF NC PROGRAM
Data input/output	Display screen	8.4" color
	Memory card input/output	○
Editing operation	USB memory input/output	○
	Part program storage size	512Kbyte(1280m)