



SMEC

NS 2000 Series

LM GUIDE TYPE
HORIZONTAL TURNING CENTER



SMEC Co., Ltd.

157-10, Goldenroot-ro, Juchon-myeon, Gimhae-si,
Gyeongsangnam-do, Korea
Tel +82 55 340 4800 / Fax +82 55 340 4740
www.smecmachinetools.com



NS 2000 Series

- | NS 2000
- | NS 2000M
- | NS 2000L
- | NS 2000LM



NS 2000 Series (A Type:6", B Type:8")

NS 2000/M/L/LM

Roller LM Guide Type Compact Turning Center

- 45 degree TORQUE TUBE TYPE bed to support heavy duty machining
- Significantly reduced non-cutting time for high efficiency machining
- Low center of gravity design minimizing vibration and thermal growth for high precision turning
- Internalized spindle motor to minimize installation footprint

Category		NS 2000A AM	NS 2000B BM	NS 2000AL ALM	NS 2000BL BLM
Chuck size	inch	6"	8"	6"	8"
Swing over bed	mm(inch)	565(22.25)	565(22.25)	565(22.25)	565(22.25)
Max turning length	mm(inch)	304(11.97) 286(11.26)	261(10.28) 243(9.57)	534(21.03) 516(20.32)	491(19.34) 473(18.63)
Spindle bore	mm(inch)	61(2.41)	76(3.0)	61(2.41)	76(3.0)
Spindle speed	rpm	6,000	4,500	6,000	4,500
Main Motor (cont./max)	kW(Hp)	11/18.561(14.76/24.81)	11/18.561(14.76/24.81)	11/18.561(14.76/24.81)	11/18.561(14.76/24.81)
Travels (X/Z)	mm(inch)	175/350(6.89/13.76)	175/350(6.89/13.76)	175/350(6.89/13.76)	175/350(6.89/13.76)
No of tool positions	EA	10 12(BMT45)	10 12(BMT45)	10 12(BMT45)	10 12(BMT45)

Non cutting time reduced, increasing productivity

Roller type LM guides on all axes provides superb traverse speeds while the wide guideway span offers enhanced stability

High rigidity bed and optimized feed system design

High torque tube rib bed design supports heavy duty machining while the pre-tensioned double anchored feed system and 6 sided x-axis slideway frame enables high precision

Maximized space efficiency design

Optimal design for part setting and exchange with hydraulic gauge and valves located at the front of the machine at operator eye-level to maximize work efficiency

Operator centered convenience features

Operator convenience maximized with features such as M-CODE based programmable tailstock, Manual Guide i and operator panel

❖ Non cutting time reduced, increasing productivity

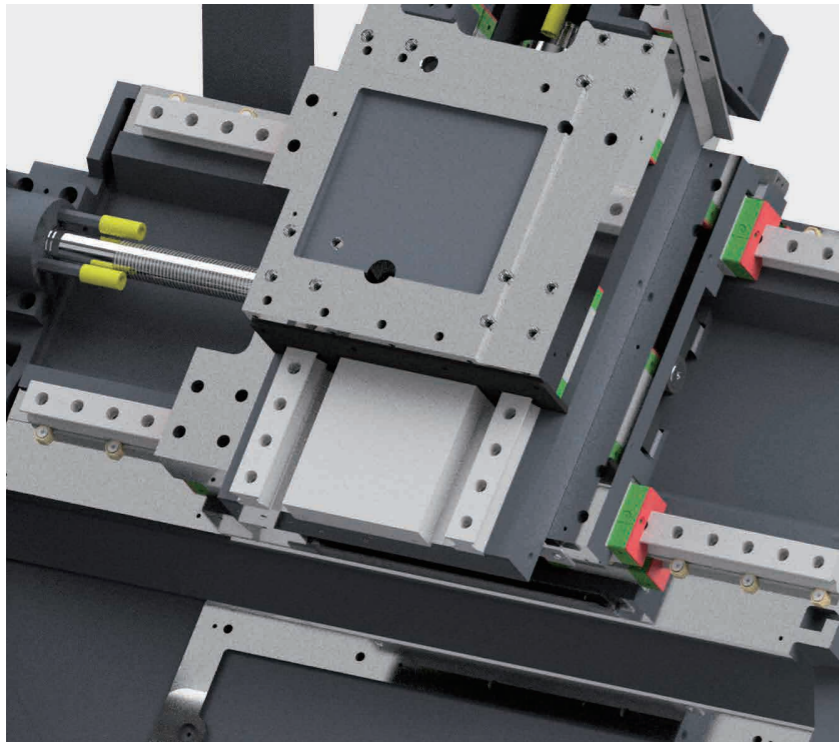

Non-cutting time reduced with use of Roller Type LM Guideway

- Superb traverse speeds with the application of Roller Type LM Guides (30~40% more rigid than Ball Type LM Guides)
- Wide guideway spans on each axis for improved stability
- Designed with fixed pretension at both ends minimize thermal growth of the ball screw
- P4 class high-precision angular bearings used as ball screw support bearings

❖ Designed for maximum space efficiency

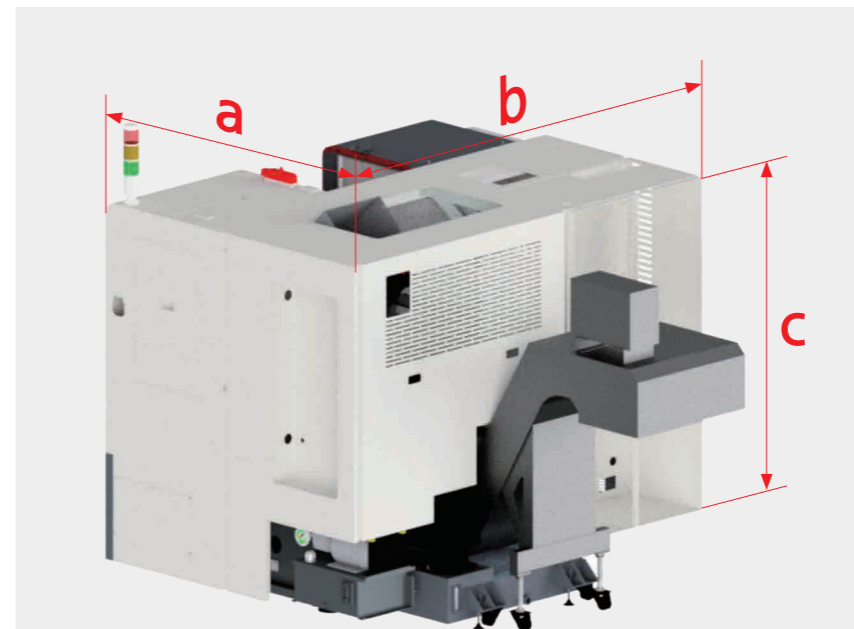

Maximized space efficiency

- Compact design minimizes the installation footprint allowing more machines to be installed and operated in the same amount of space
- Coolant tank and chip conveyor can be installed as either side or rear discharge to meet the customer's requirements

Model	Units	a	b	c
NS 2000 series	mm (inch)	1,580 (62.21)	2,120 (83.47)	1,710 (67.33)
NS 2000L series	mm (inch)	1,580 (62.21)	2,580 (101.58)	1,710 (67.33)

Machine length reduced by **25%** compared to similar models

❖ High rigidity bed and optimized feed system design

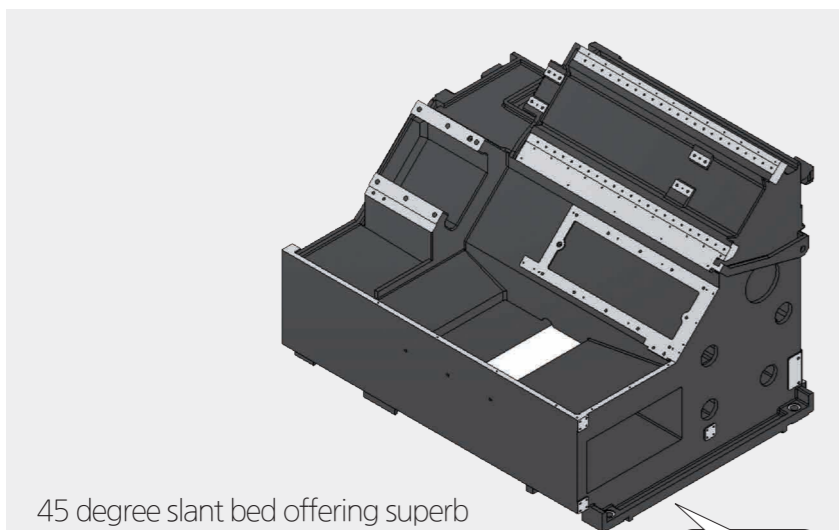

45 degree slant bed offering superb stability even during heavy duty machining

The 45 degree slant bed with high torque tube ribbing offers superb resistance to torsion and bending and provides excellent vibration suppression even during heavy duty machining, allowing for high precision machining while offering superb accessibility and chip discharge capacity

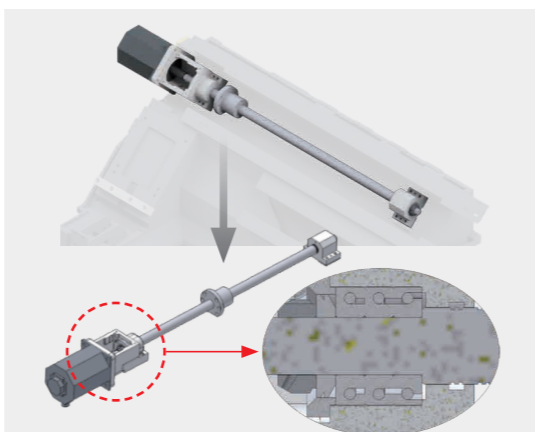
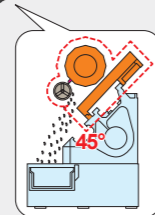

Pre-tensioned double anchored travel axis

All travel axes employ pre-tensioned double anchored ball screws to minimize thermal growth and are supported on both ends using high precision P4 angular bearings for high precision operation

- Pre-tensioned double anchored (minimize thermal growth)
- High precision angular bearing+large diameter high precision ball screws

❖ Ease of use



① Programmable tailstock

Able to operate automatically via M-CODE allowing for more productivity and convenience

② User-centric OP Panel

The QWERTY-type keyboard and high visibility buttons and effective button placement enhances ease of use

③ Easy coolant tank maintenance

When cleaning the coolant tank, the coolant tank may be removed while leaving the chip conveyor attached to the machine, making it easier to clean and maintain
※ For L Type, only available for SIDE DISCHARGE TYPE

Machine Design

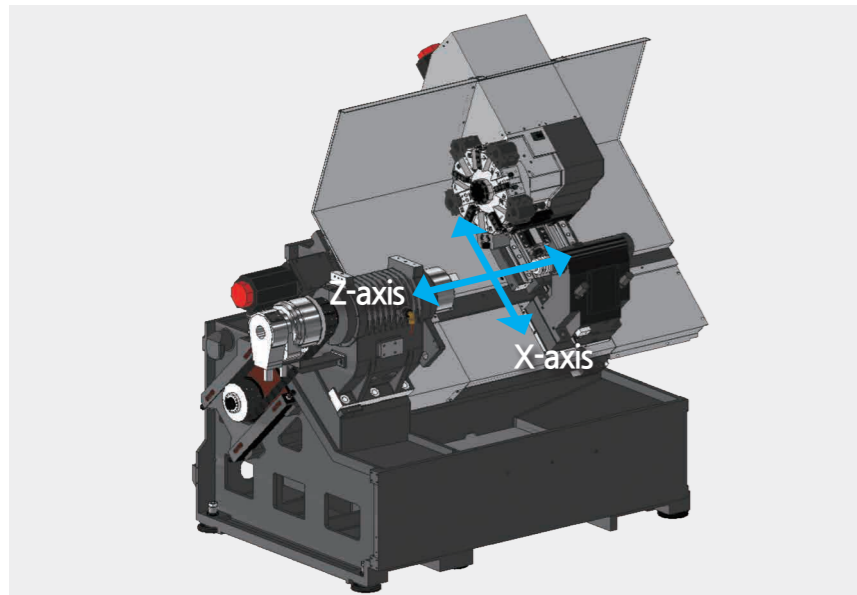

High reliability, high rigidity design

The Torque Tube Rib casting and wide guideway design offers high precision during heavy duty cutting while minimizing torsion and vibration and increasing durability

45 degree slant bed provides excellent stability during heavy duty cutting

Increased the contact area by **60%** compared to existing models for increased support rigidity

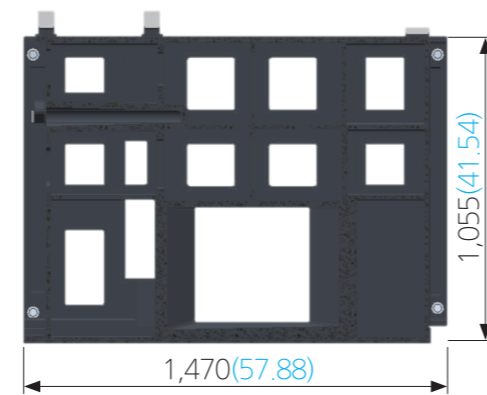

Model	Chuck size (inch)	Travel [mm (inch)]		Rapid Traverse [m/min (ipm)]	
		X-axis	Z-axis	X-axis	Z-axis
NS 2000/M (A type)	6"	175(6.89)	350(13.78)	36(1,417.33)	36(1,417.33)
NS 2000/M (B type)	8"	175(6.89)	350(13.78)	36(1,417.33)	36(1,417.33)
NSL 2000L/LM (A type)	6"	175(6.89)	580(22.84)	36(1,417.33)	36(1,417.33)
NS 2000L/LM (B type)	8"	175(6.89)	580(22.84)	36(1,417.33)	36(1,417.33)

Work Range

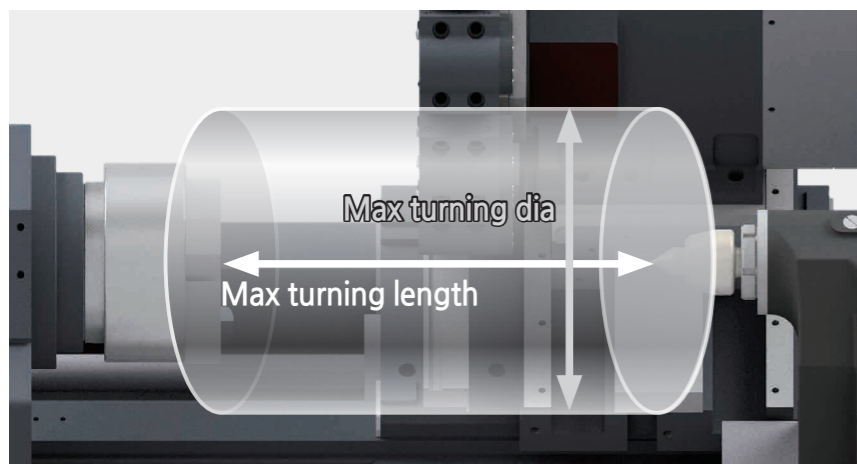

Largest-in-class work range

NS 2000/L Series (A, B type)

Max turning dia
Ø310mm (12.21 inch)

NS 2000M/LM Series (A, B type)

Max turning dia
Ø288mm (11.34 inch)

Model	Unit	Max turning dia	Max turning length
NS 2000 (A/B type)	mm (inch)	Ø310 (12.21)	304/261 (11.97/10.28)
NS 2000M (A/B type)	mm (inch)	Ø288 (11.34)	286/243 (11.26/9.57)
NSL 2000L/LM (A type)	mm (inch)	Ø310 (12.21)	534/491 (21.03/19.34)
NS 2000L/LM (B type)	mm (inch)	Ø288 (11.34)	516/473 (20.32/18.63)

Spindle



The high power motor allows both high precision and high torque machining, improving operator productivity.

NS 2000/L (A type)

Max speed Power (cont/max)
6,000 rpm **11/18.5** kW (14.76/24.81 Hp)

Torque (cont/max)
53/118 N·m (39.10/87.04 lbs.ft)

NS 2000/L (B type)

Max speed Power (cont/max)
4,500 rpm **11/18.5** kW (14.76/24.81 Hp)

Torque (cont/max)
94/211 N·m (69.34/155.63 lbs.ft)

NS 2000M/LM (A, B type)

Max speed Power (cont/max)
5,000 rpm **3.7/5.5** kW (4.97/7.38 Hp)

Torque (cont/max)
17.7/35 N·m (13.06/25.82 lbs.ft)

Model	Chuck size	Speed rpm	Power (Cont./Max) kW (Hp)	Torque (Cont./Max) N·m (lbs.ft)
NS 2000/M (A type)	6"	6,000	11/18.5 (14.76/24.81)	53/118 (39.10/87.04)
NS 2000/M (B type)	8"	4,500	11/18.5 (14.76/24.81)	94/211 (69.34/155.63)
NSL 2000L/LM (A type)	6"	6,000	11/18.5 (14.76/24.81)	53/118 (39.10/87.04)
NS 2000L/LM (B type)	8"	4,500	11/18.5 (14.76/24.81)	94/211 (69.34/155.63)

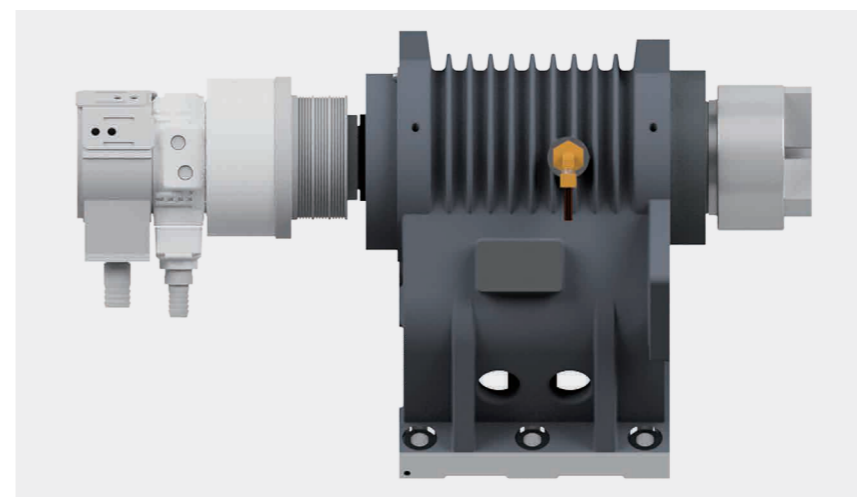

Radiator Fin Headstock to Minimize Thermal Growth

The radiator fin-like rib structure minimizes thermal growth in the spindle, preventing loss of precision due to increases in temperature. While the symmetrically designed headstock minimizes the impact of thermal growth.

The set of 3 high precision Angular Ball Bearings on the front end of the spindle and a Double Row of Cylindrical Roller Bearings in the rear ensures high precision, high speed machining performance

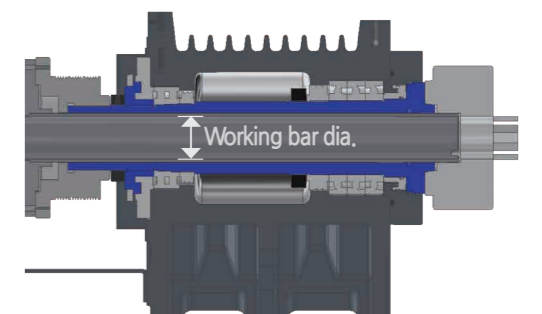

Model	Spindle bore [mm (inch)]	Working bar dia [mm (inch)]	Spindle nose (ASA)
NS 2000/M (A type)	Ø61 (2.41)	Ø51 (2.01)	A2-5
NS 2000/M (B type)	Ø76 (3.00)	Ø67 (2.64)	A2-6
NSL 2000L/LM (A type)	Ø61 (2.41)	Ø51 (2.01)	A2-5
NS 2000L/LM (B type)	Ø76 (3.00)	Ø67 (2.64)	A2-6

Turret

HIGH SPEED, HEAVY DUTY SERVO TURRET

NS 2000/L : 10 Stations (□25×25, Ø40)
(□1"×1", Ø1.58")



HIGH SPEED MILL TURRET (BMT45)

NS 2000M/LM : 12 Stations (□20×20, Ø32)
(□0.79"×0.79", Ø1.26")

Significantly reduced non-cutting time with 0.2 second turret indexing time

Turret indexing employs an internally developed method of Non Stop Random Index that uses a high powered Servo Index Motor to allow 0.2 second single station turret indexing. And the large diameter ø145 Curvic Coupling significantly increases the clamping force and indexing accuracy

Turret indexing time No. of tool positions
0.2sec **10**EA

BMT Milling Turret (AM/BM Type)

This 12 tool position turret with the largest in class curvic coupling and powerful clamping force is capable of accepting a rotary tool in every tool position and allows a variety of machining operations with a single set-up

The best in class tool holders ensure high rigidity, high precision machining and the non-stop turret indexing in either direction minimizes the turret index time down to 0.15 seconds per station.

Turret indexing time No. of tool positions
0.15sec **12**EA

Spindle Drive

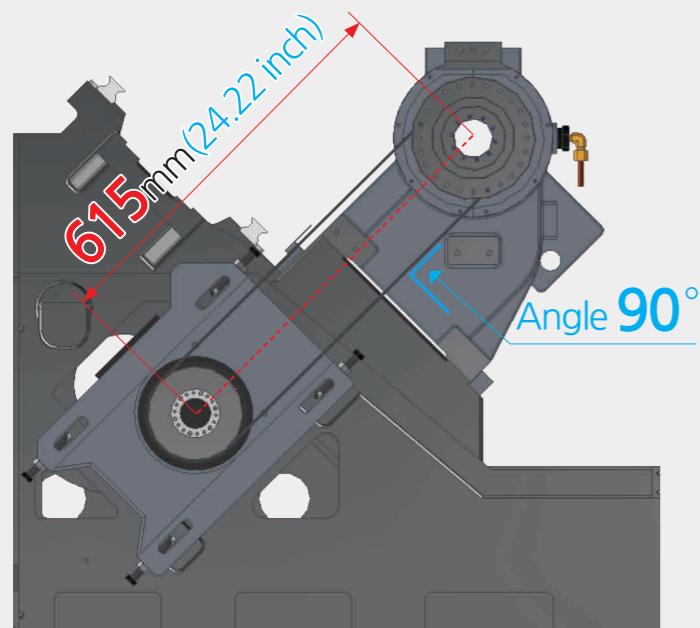

- Reduced distance between spindle and spindle motor compared to similar models
- Internalized spindle motor design reduces installation footprint
- Orthogonal tension minimizes thermal growth

Distance from Spindle to Spindle Motor
615mm(24.22 inch)

Distance compared to similar models
12% shorter

Accessories [Optional]

Oil skimmer

Continuously cleans the coolant by removing waste oils

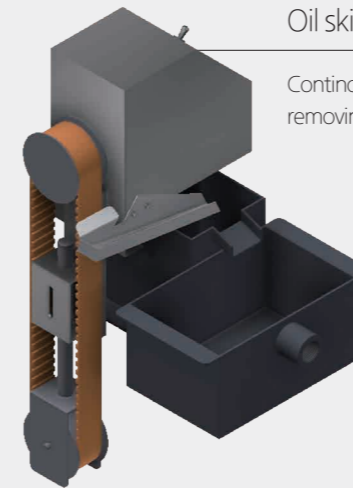

Autodoor

Used to quickly open/close the operator door via program to increase productivity in an automation line.

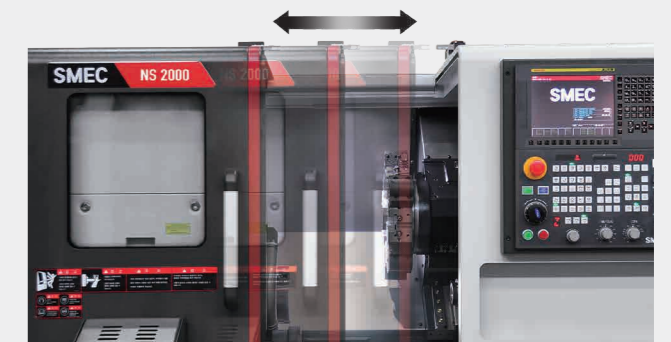

Tool presetter

Provides faster and more precise tool setup, checking for tool wear and compensation

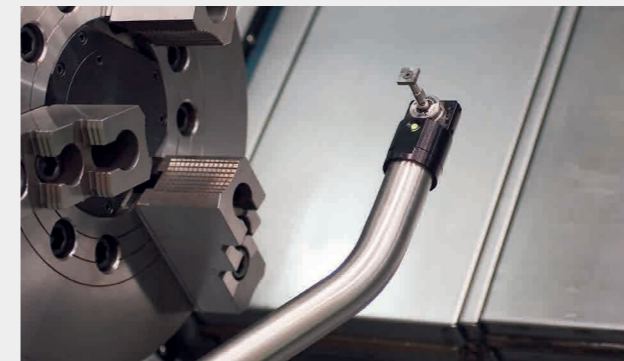

Air blow

Used to automatically remove chips from the chuck after machining and used for safe loading of the chuck in an automated line.

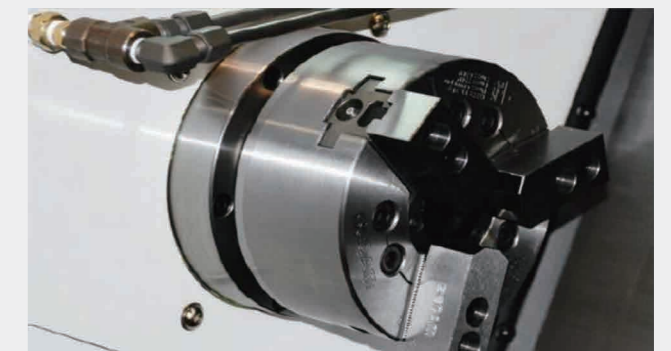

Part catcher

Used to receive the completed part and discharge them into a container attached to the exterior of the machine.

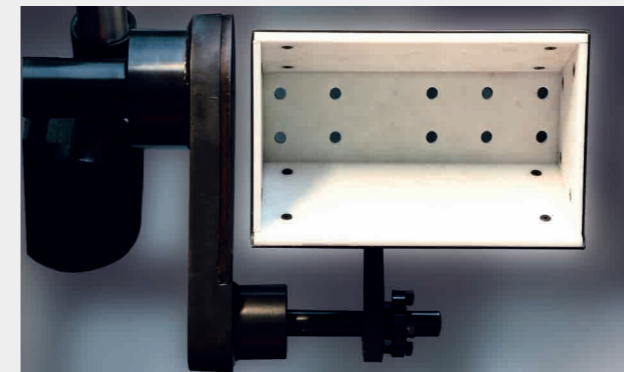

Chip conveyor

Used to discharge chips created during machining

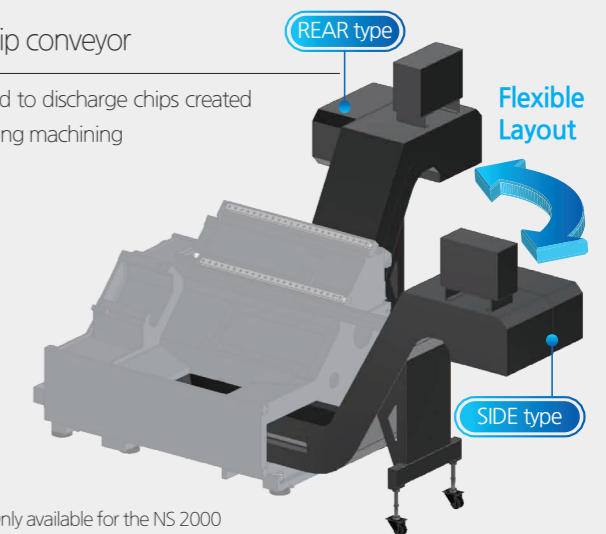

※ Only available for the NS 2000

SMEC FANUC i series



NS 2000

- 10.4" LCD color display
- Part program size 2MB
- High quality designed OP Panel
- SMEC Custom S/W Manual guide i



NS 2000M

- 10.4" LCD color display
- Part program size 2MB
- High quality designed OP Panel
- SMEC Custom S/W
- Conversational programming, Manual guide i

SMEC Custom S/W displayed using MDI's button or OP Panel's button

SMEC Custom S/W displayed using MDI's button or OP Panel's button

◀ **CUSTOM** : Provide operator convenience and improve productivity using the support function for tool management and additional device setting.



M/G-Code check function

Allows the operator to directly read the M/G-Code on the machine for easy application programming

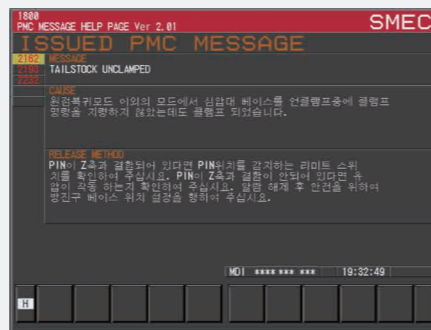

PMC alarm check function

When a PMC alarm occurs, the cause and countermeasures are described in detail, making operation and maintenance more convenient

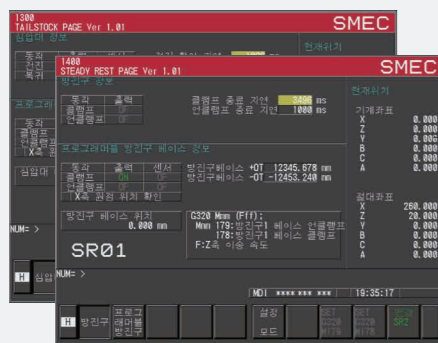

Easy tailstock setting

Easily configure a variety of functions such as travel limiting, origin setting and signal check

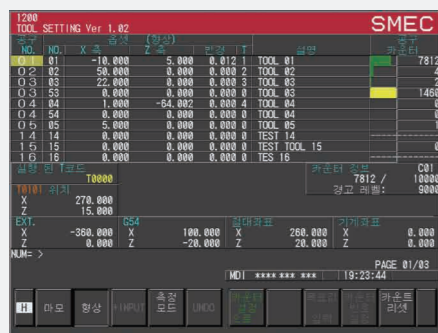

Display only the necessary tools and offsets and check the configured counter at the same time

Tool information and setting management mode



Counter for each T-Code

Machining Solution (STD)

S4 (SMEC SMOOTH SURFACE SYSTEM) Package

High performance NC options to improve machining performance provided as standard

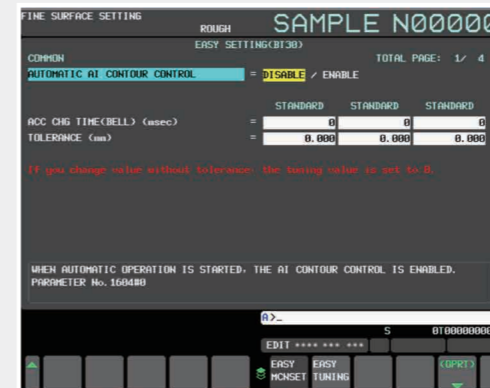

Without S4 Package

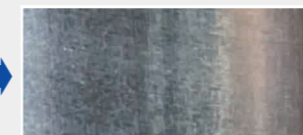

With S4 Package

15 inch LCD monitor standard	
AICC II (AI Contour Control II)	Efficient accel/deceleration (200 block look ahead)
Jerk control	Speed control during acceleration changes
Smooth tolerance plus control	Stable curved shape forming
Machining conditions selection function	Adjust accuracy level according to machining conditions
Machining quality selection function	
Manual Guide i	Visual machining check and setup guide
Data server	Transfer large program files
Part program storage	2MB (5,120M)
Number of registered programs	1,000ea

IoT Solution (OPT)



NC-Gate Basic Platform



IoT-Gate Expansion Platform

NC-Gate / IoT-Gate

The NC-Gate / IoT-Gate that was developed in-house with our ICT technology is a universal gateway that not only interworks with our machine tools, but machine tools from other manufacturers, robots, automation equipment, and analog / digital sensors as a network device capable of bi-directional communication.

Supported drivers : Fanuc / Mitsubishi / Siemens NC, Modbus TCP, DeviceNet, Profibus, Ethernet, AI/DI/DO



Provides key performance indicators and displays target achievement

- Indicators : achievement rate, productivity, process defect rate, equipment and factory usage, quality defect rate, lead time, and average cycle time



Provides figures and graphs of overall equipment effectiveness

- Availability, performance, quality, etc.



Provides operation status and alarm information in case of problems in the production line



Remote control and operation

- Emergency stop switch, program editing, etc.



Problem diagnosis via remote control

- Provide remote diagnosis services to users via the IoT solution

Power-Torque Diagram

NS 2000/L (A type)

Max Spindle Speed

6,000rpm

Power (Cont/Max)

11/18.5kW
(14.76/24.81 Hp)

Torque (Cont/Max)

53/118N·m
(39.10/87.04 lbs-ft)

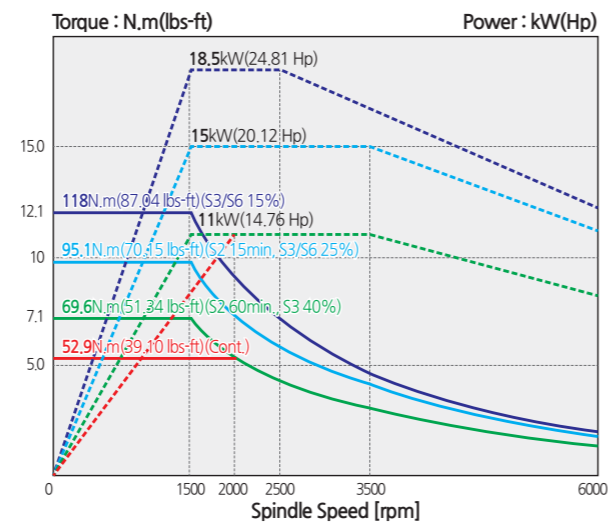

NS 2000/L (B type)

Max Spindle Speed

4,500rpm

Power (Cont/Max)

11/18.5kW
(14.76/24.81 Hp)

Torque (Cont/Max)

94/211N·m
(69.34/155.63 lbs-ft)

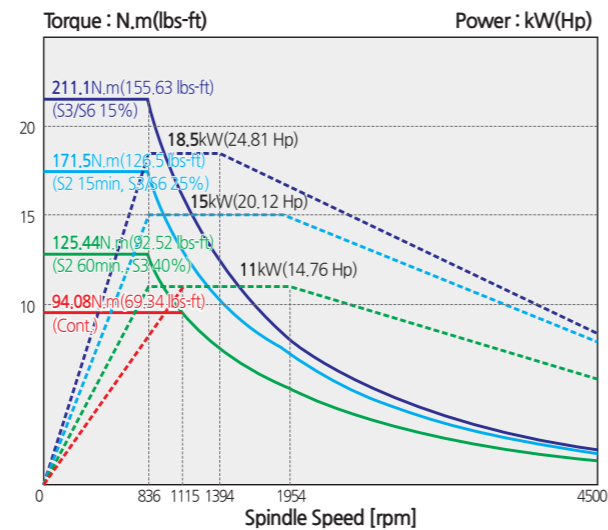

NS 2000M/LM (A, B type)

Milling Motor Torque Diagram

Max Spindle Speed

5,000rpm

Power (Cont/Max)

3.7/5.5kW
(4.97/7.38 Hp)

Torque (Cont/Max)

17.7/35N·m
(13.06/25.82 lbs-ft)

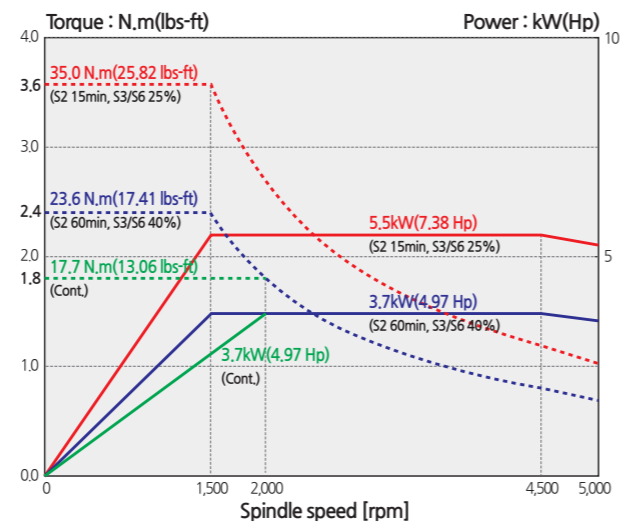

Cutting Performance

◆ O.D Cutting

Cutting dia.	mm(inch)	Ø45(1.78)
Cutting depth	mm(inch)	4.5(0.18)
Cutting speed	m/min(ipm)	212(8,346.46)
Spindle speed	rpm	1,500
Feedrate	mm/rev(inch/rev)	0.45(0.018)
Chip removal rate	cc/min(oz/min)	429(14.51)

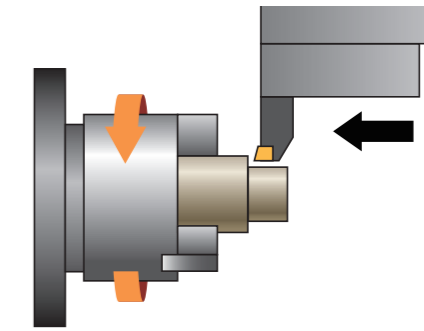

◆ U-Drill Cutting

U-drill dia.	mm(inch)	Ø37.5(1.48)
Cutting depth	mm(inch)	70(2.26)
Cutting speed	m/min(ipm)	180(7,086.62)
Spindle speed	rpm	1,530
Feedrate	mm/rev(inch/rev)	0.23(0.010)
Chip removal rate	cc/min(oz/min)	388(13.12)

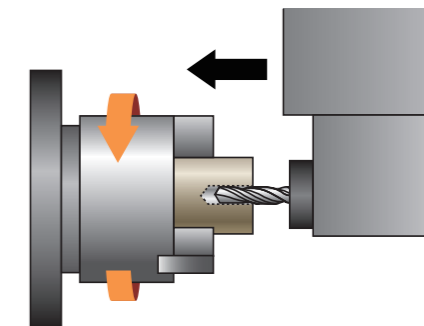

◆ Tap

Tap size	mm	M16×2
Cutting depth	mm(inch)	30(1.19)
Cutting speed	m/min(ipm)	10(393.71)
Spindle speed	rpm	199
Feedrate	mm/rev(inch/rev)	2(0.079)

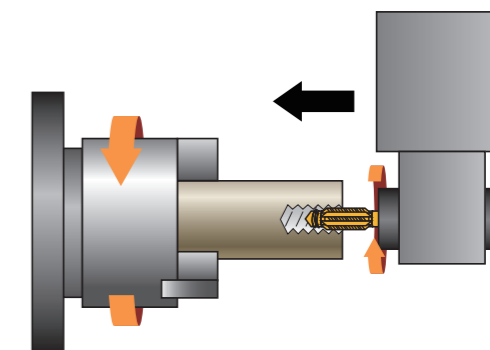

※ The above data is based on internal testing. Values may change depending on cutting conditions.

Turret Interference

NS 2000/L

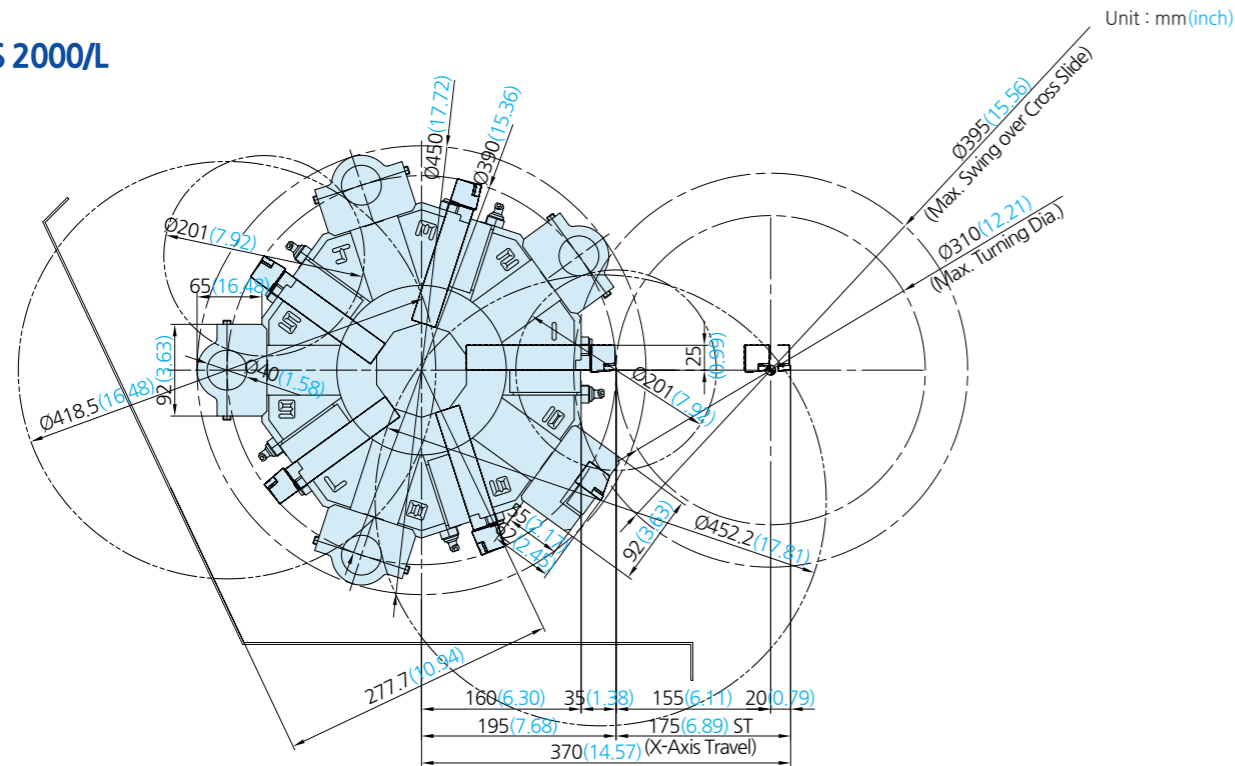

NS 2000M/LM

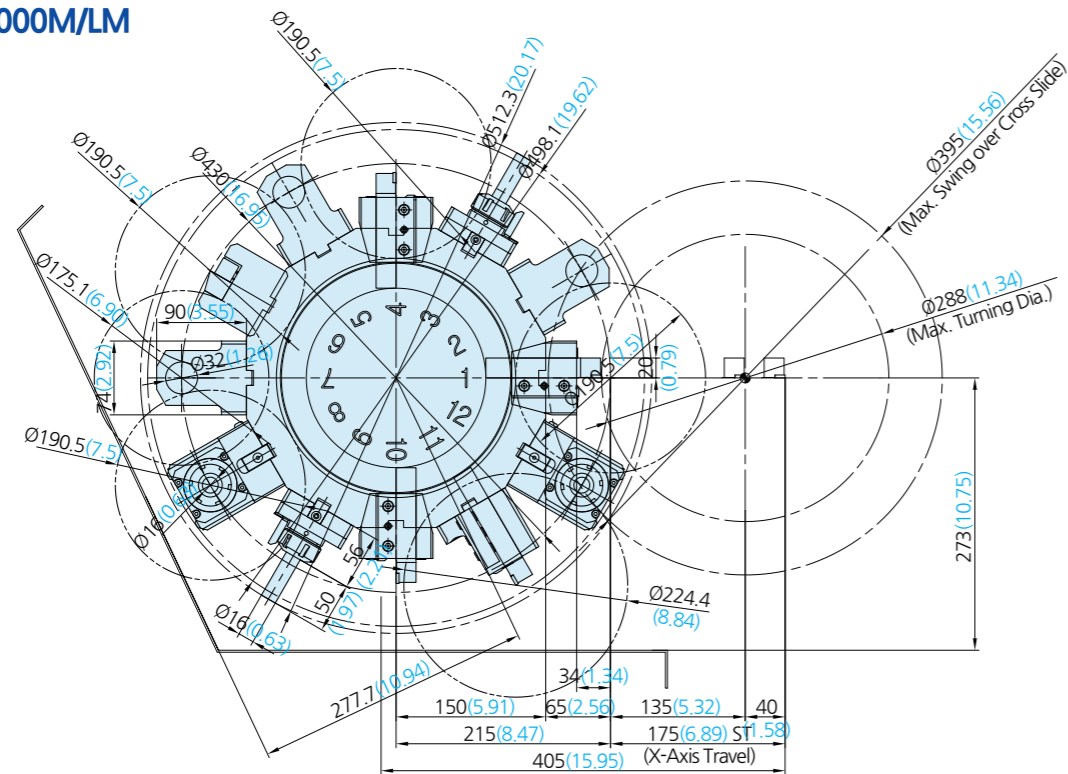

Machine Dimensions

Top view



Front view

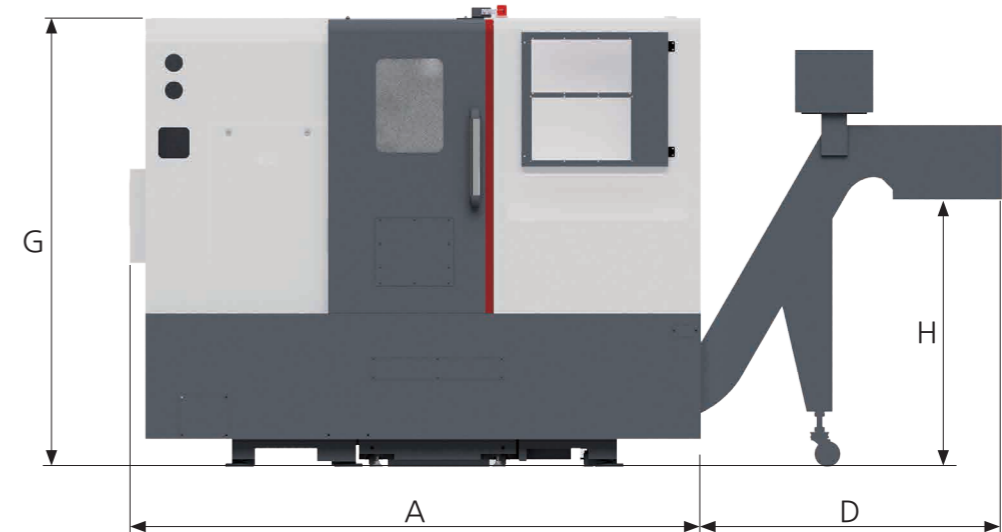

Model	A (Machine Length)	B (Width incl. OP Panel)	C (Max. Machine Width)	D (with SIDE Chip Conveyor)	E (Machine Width)	F (with REAR Chip Conveyor)	G (Packaged Machine Height)	H (Chip Conveyor Discharge Height)
NS 2000/M	2,120(83.47)	1,580(62.21)	2,730(107.49)	1,130(107.49)	1,535(60.44)	930(36.62)	1,710(67.33)	970(38.19)
NS 2000L/LM	2,580(101.58)	1,580(62.21)	2,730(107.49)	1,130(107.49)	1,535(60.44)	940(37.00)	1,710(67.33)	970(38.19)

Standard / Optional

Various options available to meet user's requirements

● : Standard ○ : Optional △ : Discuss X : N/A

Category	Detailed Description	NS 2000	NS 2000M	NS 2000L	NS 2000LM	
Spindle	3 jaw open-center chuck	●	●	●	●	
	3 jaw closed-center chuck	○	○	○	○	
	Soft jaw (3set)	●	●	●	●	
	Hard jaw (1set)	○	○	○	○	
	Chuck clamp footswitch	●	●	●	●	
	Dual pressure chucking	○	○	○	○	
	C-axis control (0.001°)	X	●	X	●	
	Chuck clamp confirmation	●	●	●	●	
	Chuck dual footswitch	○	○	○	○	
	Turret	Tool holder	●	●	●	●
Rotary holder type		BMT	X	●	X	●
Rotary holder (axial)		Collet-type, 2EA	X	●	X	●
Rotary holder (radial)		Collet-type, 2EA	X	●	X	●
Rotary holder (axial)		Adapter-type	X	○	X	○
Rotary holder (radial)		Adapter-type	X	○	X	○
Boring bar sleeve (same as U-drill holder sleeve)			●	●	●	●
Drill socket			●	●	●	●
U-drill holder			●	●	●	●
U-drill cap			●	●	●	●
Tailstock	Programmable tailstock	X	X	○	○	
	Live center (standard with tailstock)	○	○	○	○	
	High precision live center	○	○	○	○	
	Tailstock 2 step pressure system	○	○	○	○	
	Quill forward/reverse confirmation	○	○	○	○	
	Tailstock footswitch	○	○	○	○	
	Coolant & Air Blow	Standard coolant (nozzle)	○	○	○	○
Coolant above chuck		○	○	○	○	
Coolant gun		○	○	○	○	
TSC for chuck (for special chuck)		△	△	△	△	
Bed flushing		○	○	○	○	
Air blower (above chuck)		○	○	○	○	
Rotary tool holder TSC		○	○	○	○	
Tailstock air blower		X	X	X	X	
Turret tool air blower		X	X	X	X	
Air gun		○	○	○	○	
Coolant & Air Blow	Through spindle air blower (for special chuck)	○	○	○	○	
	Coolant pump	4.5Bar	●	●	●	●
		7Bar	○	○	○	○
		10Bar	○	○	○	○
		14.5Bar	○	○	○	○
		20Bar	○	○	○	○
	Power coolant system (for automation solutions)	△	△	△	△	
	Coolant chiller	○	○	○	○	

Category	Detailed Description	NS 2000	NS 2000M	NS 2000L	NS 2000LM	
Chip Disposal	Coolant tank	140L	●	●	●	●
	Chip conveyor (Hinge/ Scraper / Screw)	Side	○	○	○	○
		Rear	○	○	○	○
	Special chip conveyor (drum filter)		△	△	△	△
	Chip bucket	Fixed 380L	○	○	○	○
Safety Features	Door interlock		●	●	●	●
	Back-spin torque limiter (BST)		X	X	X	X
	Torque limiter		X	X	X	X
	Full splash guard		●	●	●	●
	Chuck hyd pressure interlock		X	X	X	X
	3 step patrol lamp and buzzer		●	●	●	●
	Lamp for electrical cabinet		X	X	X	X
Remote MPG		X	X	X	X	
Electrical	Work counter	Digital	△	△	△	△
	Total counter	Digital	△	△	△	△
	Tool counter	Digital	△	△	△	△
	Multi counter	6EA	△	△	△	△
		9EA	△	△	△	△
	Grounded circuit breaker		△	△	△	△
	AVR(Auto Voltage Regulator)		X	X	X	X
	Transformer	25kVA	○	○	○	○
		30kVA	△	△	△	△
	Auto Power Off		○	○	○	○
Measurement	Tool Presetter	Manual	○	○	○	○
	Tool Presetter	Auto	○	○	○	○
	Part seat (air gap) measuring device (for special chuck)	TACO	△	△	△	△
		SMC	△	△	△	△
	Linear scale	X-axis	○	○	○	○
Z-axis	○	○	○	○		
Environmental	Coolant level gauge (requires chip conveyor)		○	○	○	○
	Air conditioner for electrical cabinet		○	○	○	○
	Dehumidifier		△	△	△	△
	Oil mist collector		○	○	○	○
	Oil skimmer		○	○	○	○
Automation	MQL(Minimal Quantity Lubrication)		○	○	○	○
	Auto door		○	○	○	○
	Auto shutter (for automation solutions)		○	○	○	○
	Sub controller		△	△	△	△
	Barfeeder interface		△	△	△	△
	Additional M-codes (4 pairs)		△	△	△	△
	Automation interface		△	△	△	△
	I/O expansion (including both IN and OUT)	16 contacts	△	△	△	△
		32 contacts	△	△	△	△
	Parts catcher		○	○	○	○
Parts conveyor (parts catcher required)		X	X	X	X	
Hydraulic Supply	Standard hydraulic cylinder	Open-center	●	●	●	●
	Standard hydraulic unit	35Bar / 15L	X	X	X	X
35Bar / 20L		●	●	●	●	

※ For detailed information, please contact your local SMEC dealer.

Tooling System

Unit : mm(inch)

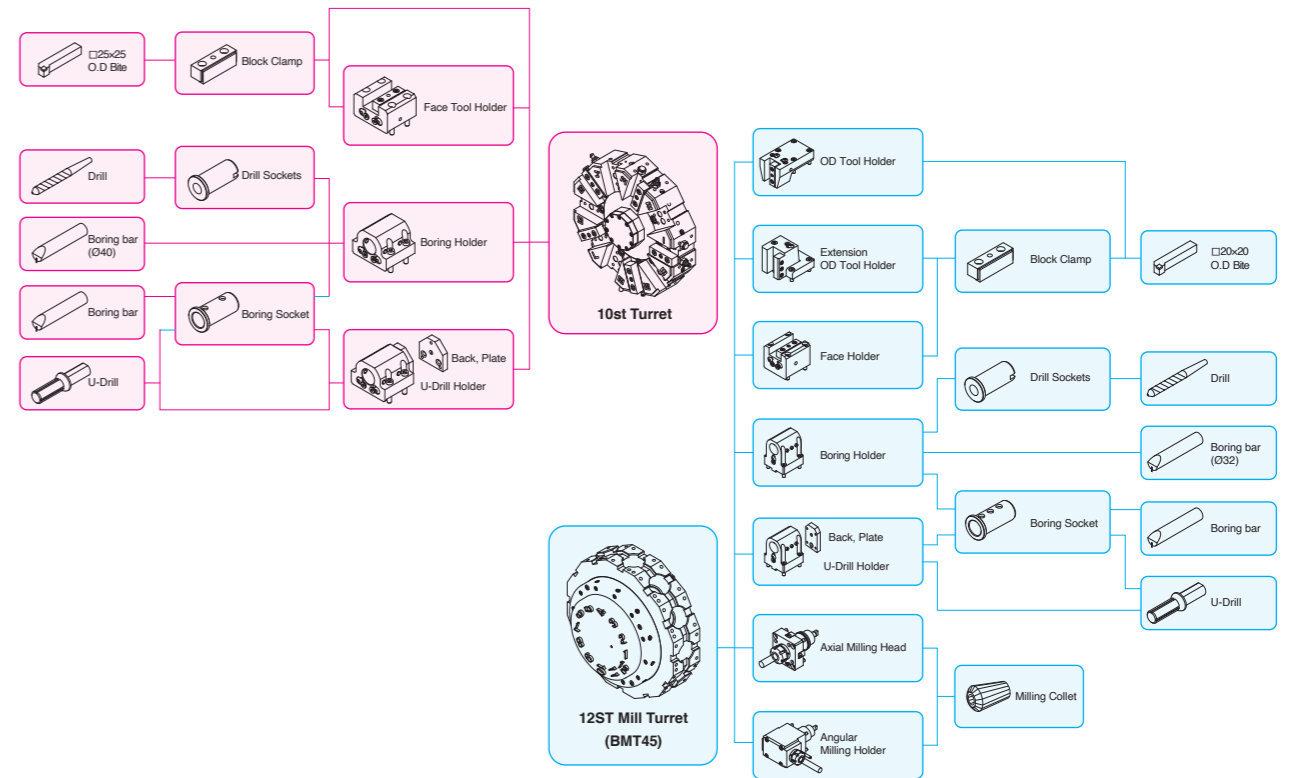

Standard Tooling

ITEM/ MODEL	NS 2000/L		NS 2000M/LM			
	6 inch	8 inch	6 inch	8 inch		
Static Holder	Clamper	5	5	6	6	
	OD Holder	-	-	1	1	
	OD Holder	Extension	-	-	3	3
Boring Holder	Face Holder	1	1	1	1	
	ID Holder	Single (Ø40, Ø1 1/2")	3	3	2	2
	U-Drill Holder	Cap	1	1	1	1
Milling Holder	Straight Milling Holder	Standard	-	-	2	2
		T.T.C	-	-	-	-
	Angular Milling Holder	Standard	-	-	2	2
T.T.C		-	-	-	-	
Socket	Boring	Ø8(Ø5/16")	1	1	1	1
		Ø10(Ø3/8")	1	1	1	1
		Ø12(Ø1/2")	1	1	1	1
		Ø16(Ø5/8")	1	1	1	1
		Ø20(Ø3/4")	1	1	1	1
		Ø25(Ø1")	1	1	1	1
		Ø32(Ø1 1/4")	1	1	-	-
	Drilling	MT1	1	1	1	1
		MT2	1	1	1	1
	ER Collet		-	-	-	-

Work Range

NS 2000A[AL]

Unit : mm(inch)

O.D Tool

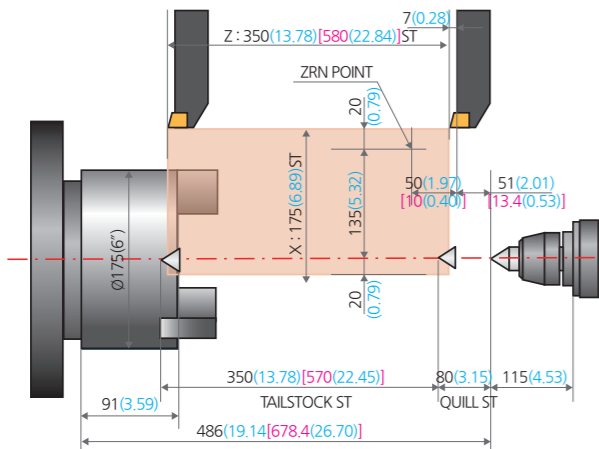

I.D Tool

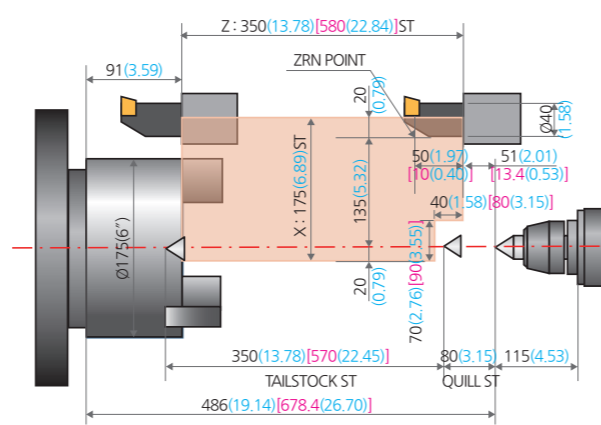

NS 2000B[BL]

O.D Tool

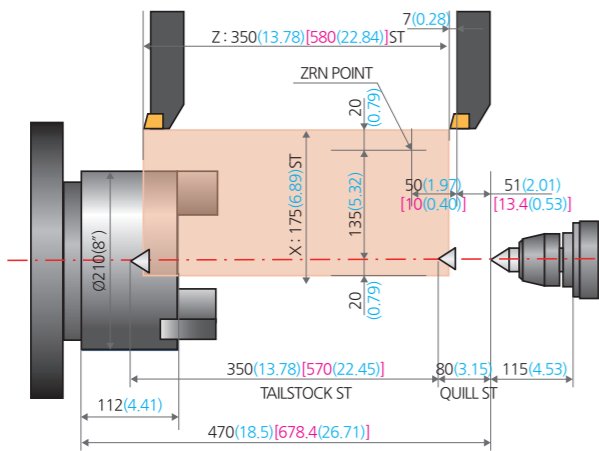

I.D Tool

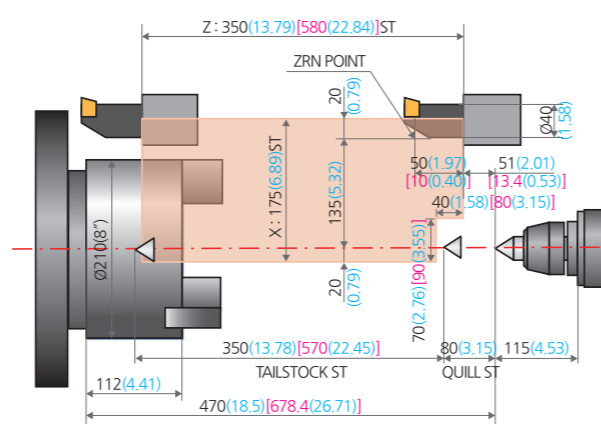

Work Range

NS 2000AM[ALM]

Unit : mm(inch)

O.D Tool

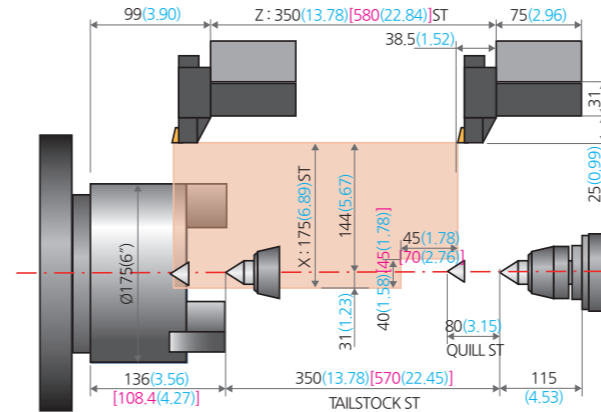

Ext O.D Tool

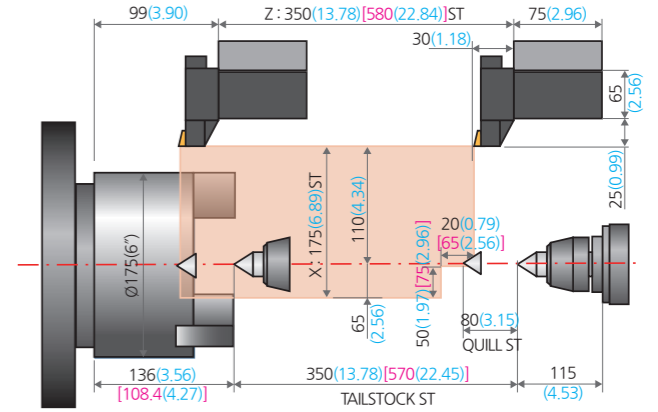

I.D Tool

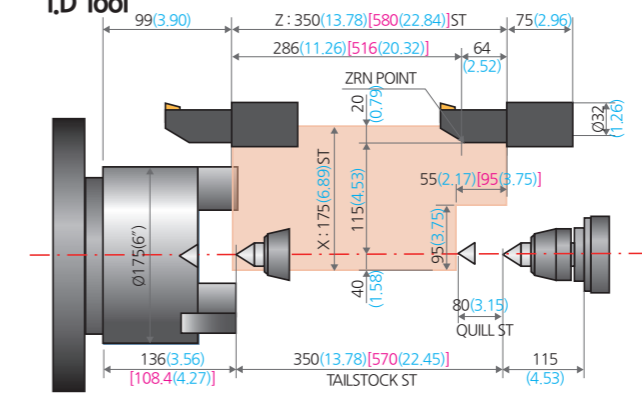

Axial milling head (ER25)

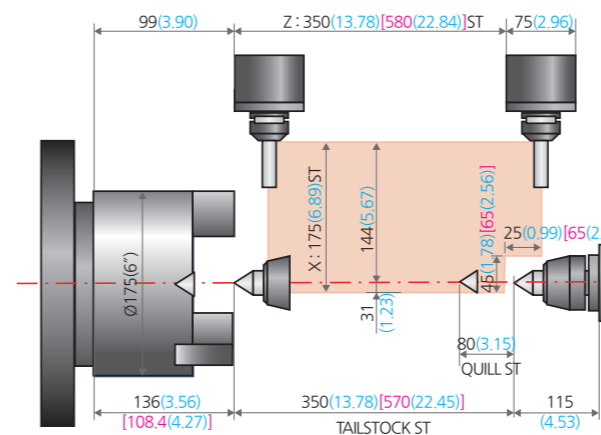

Angular milling head(ER25)

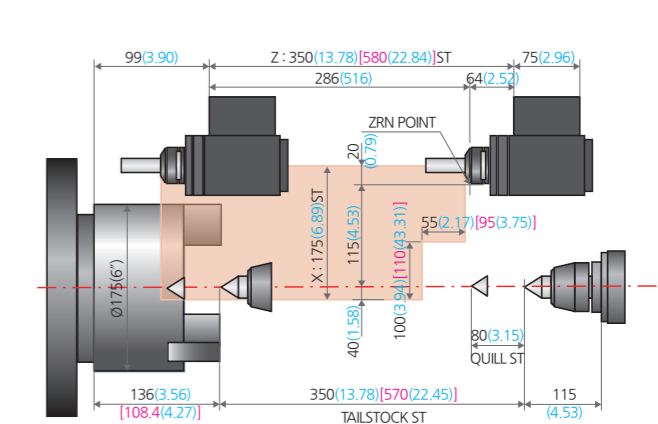

Work Range

NS 2000BM[BLM]

Unit : mm(inch)

O.D Tool

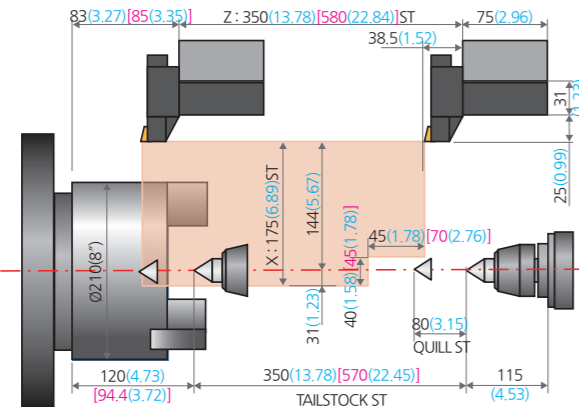

Ext O.D Tool

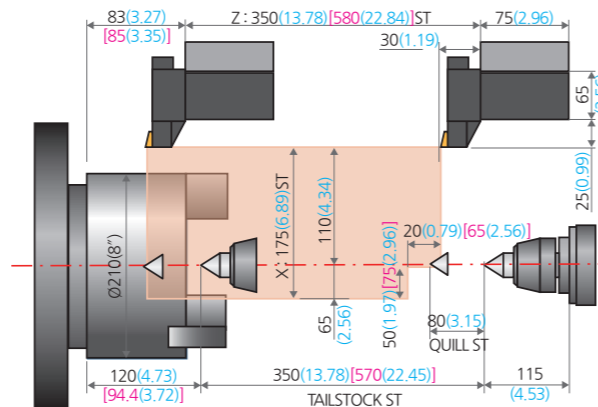

I.D Tool

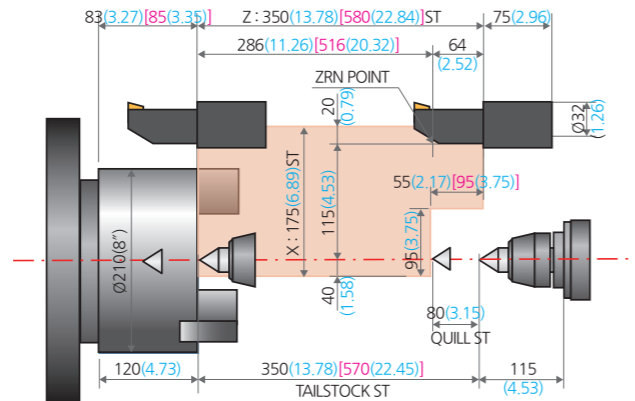

Axial milling head (ER25)

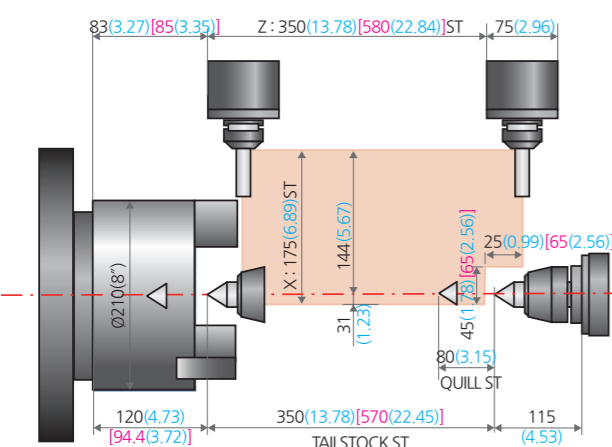

Angular milling head(ER25)

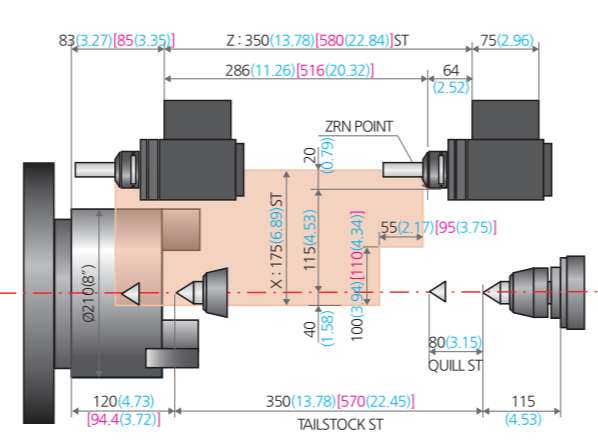

Machine Specifications

DESCRIPTION		NS 2000		NS 2000M		
		A type	B type	A type	B type	
Chuck	Chuck size	inch	6"	8"	6"	8"
Capacity	Swing over bed	mm(inch)	565(22.25)	565(22.25)	565(22.25)	565(22.25)
	Swing over cross-slide	mm(inch)	395(15.56)	395(15.56)	395(15.56)	395(15.56)
	Max turning diameter	mm(inch)	310(12.21)	310(12.21)	288(11.34)	288(11.34)
	Max turning length	mm(inch)	304(11.97)	261(10.28)	286(11.25)	243(9.57)
Spindle	Spindle speed	rpm	6,000	4,500	6,000	4,500
	Spindle nose	ASA	A2-5	A2-6	A2-5	A2-6
	Draw tube ID	mm(inch)	52(2.05)	68(2.68)	52(2.05)	68(2.68)
	Spindle bore	mm(inch)	61(2.41)	76(3.00)	61(2.41)	76(3.00)
	Spindle motor (cont/max)	kW(Hp)	11/18.5(14.76/24.81)	11/18.5(14.76/24.81)	11/18.5(14.76/24.81)	11/18.5(14.76/24.81)
Travels	X-axis stroke	mm(inch)	175(6.89)	175(6.89)	175(6.89)	175(6.89)
	Z-axis stroke	mm(inch)	350(13.78)	350(13.78)	350(13.78)	350(13.78)
	X-axis rapid traverse	m/min(ipm)	36(1,417.33)	36(1,417.33)	36(1,417.33)	36(1,417.33)
	Z-axis rapid traverse	m/min(ipm)	36(1,417.33)	36(1,417.33)	36(1,417.33)	36(1,417.33)
Turret	No of tool positions	ea	10	10	12(BMT45)	12(BMT45)
	OD tool size	mm(inch)	□25×25(□1×1)	□25×25(□1×1)	□20×20(□0.79×0.79)	□20×20(□0.79×0.79)
	Boring bar diameter	mm(inch)	40(1.58)	40(1.58)	32(1.26)	32(1.26)
	Indexing time	sec	0.20	0.20	0.15	0.15
	Rotary tool speed	rpm	-	-	5,000	5,000
	Rotary tool motor (cont/max)	kW(Hp)	-	-	3.7/5.5(4.97/7.38)	3.7/5.5(4.97/7.38)
Tailstock	Quill diameter	mm(inch)	65(2.56)	65(2.56)	65(2.56)	65(2.56)
	Quill stroke	mm(inch)	80(3.15)	80(3.15)	80(3.15)	80(3.15)
	Tailstock travel	mm(inch)	350(13.78)	350(13.78)	350(13.78)	350(13.78)
	Quill taper	MT	MT4	MT4	MT4	MT4
Machine	Size [with SIDE chip conveyor] LxWxH	mm (inch)	2,120(3,250) × 1,580 × 1,710 (83.47[127.96] × 62.21 × 67.33)	2,120(3,250) × 1,580 × 1,710 (83.47[127.96] × 62.21 × 67.33)	2,120(3,250) × 1,580 × 1,710 (83.47[127.96] × 62.21 × 67.33)	2,120(3,250) × 1,580 × 1,710 (83.47[127.96] × 62.21 × 67.33)
	Size [with REAR chip conveyor] LxWxH	mm (inch)	2,120 × 1,580(2,535) × 1,710 (83.47 × 62.21[99.81] × 67.33)	2,120 × 1,580(2,535) × 1,710 (83.47 × 62.21[99.81] × 67.33)	2,120 × 1,580(2,535) × 1,710 (83.47 × 62.21[99.81] × 67.33)	2,120 × 1,580(2,535) × 1,710 (83.47 × 62.21[99.81] × 67.33)
	Weight	kg(lb)	2,850(6,283.18)	2,940(6,481.60)	3,100(6,834.34)	3,190(7,032.75)
	Coolant pump capacity	kW(Hp)	1.1(1.48)	1.1(1.48)	1.1(1.48)	1.1(1.48)
	Coolant tank capacity	Liter(gal)	140(36.99)	140(36.99)	140(36.99)	140(36.99)
ELECTRIC POWER SUPPLY		kVA/V	25/220	25/220	25/220	25/220
CONTROLLER			FANUC Oi-TF Plus			

※ Design and specifications are subject to change without notice.

[] : Option

NS 2000 Series

CNC TURNING CENTER

Machine Specifications

DESCRIPTION		NS 2000L		NS 2000LM		
		A type	B type	A type	B type	
Chuck	Chuck size	inch	6"	8"	6"	8"
Capacity	Swing over bed	mm(inch)	565(22.25)	565(22.25)	565(22.25)	565(22.25)
	Swing over cross-slide	mm(inch)	395(15.56)	395(15.56)	395(15.56)	395(15.56)
	Max turning diameter	mm(inch)	310(12.21)	310(12.21)	288(11.34)	288(11.34)
	Max turning length	mm(inch)	534(21.03)	491(19.34)	516(20.32)	473(18.63)
Spindle	Spindle speed	rpm	6,000	4,500	6,000	4,500
	Spindle nose	ASA	A2-5	A2-6	A2-5	A2-6
	Draw tube ID	mm(inch)	52(2.05)	68(2.68)	52(2.05)	68(2.68)
	Spindle bore	mm(inch)	61(2.41)	76(3.00)	61(2.41)	76(3.00)
	Spindle motor (cont/max)	kW(Hp)	11/18.5(14.76/24.81)	11/18.5(14.76/24.81)	11/18.5(14.76/24.81)	11/18.5(14.76/24.81)
Travels	X-axis stroke	mm(inch)	175(6.89)	175(6.89)	175(6.89)	175(6.89)
	Z-axis stroke	mm(inch)	580(22.84)	580(22.84)	580(22.84)	580(22.84)
	X-axis rapid traverse	m/min(ipm)	36(1,417.33)	36(1,417.33)	36(1,417.33)	36(1,417.33)
	Z-axis rapid traverse	m/min(ipm)	36(1,417.33)	36(1,417.33)	36(1,417.33)	36(1,417.33)
Turret	No of tool positions	ea	10	10	12(BMT45)	12(BMT45)
	OD tool size	mm(inch)	□25×25(□1×1)	□25×25(□1×1)	□20×20(□0.79×0.79)	□20×20(□0.79×0.79)
	Boring bar diameter	mm(inch)	40(1.58)	40(1.58)	32(1.26)	32(1.26)
	Indexing time	sec	0.20	0.20	0.15	0.15
	Rotary tool speed	rpm	-	-	5,000	5,000
	Rotary tool motor (cont/max)	kW(Hp)	-	-	3.7/5.5(4.97/7.38)	3.7/5.5(4.97/7.38)
	Quill diameter	mm(inch)	75(2.96)	75(2.96)	75(2.96)	75(2.96)
Tailstock	Quill stroke	mm(inch)	80(3.15)	80(3.15)	80(3.15)	80(3.15)
	Tailstock travel	mm(inch)	580(22.84)	580(22.84)	580(22.84)	580(22.84)
	Quill taper	MT	MT4	MT4	MT4	MT4
	Size [with SIDE chip conveyor] LxWxH	mm (inch)	2,580(3,710) × 1,580 × 1,710 (101.58(146.07) × 62.21 × 67.33)		2,580(3,710) × 1,580 × 1,710 (101.58(146.07) × 62.21 × 67.33)	
Size [with REAR chip conveyor] LxWxH	mm (inch)	2,580 × 1,580(2,520) × 1,710 (101.58 × 62.21(99.22) × 67.33)		2,580 × 1,580(2,520) × 1,710 (101.58 × 62.21(99.22) × 67.33)		
Machine	Weight	kg(lb)	3,350(7,385.49)	3,400(7,495.72)	3,500(7,495.72)	3,550(7,826.42)
	Coolant pump capacity	kW(Hp)	1.1(1.48)	1.1(1.48)	1.1(1.48)	1.1(1.48)
	Coolant tank capacity	Liter(gal)	140(36.99)	140(36.99)	140(36.99)	140(36.99)
	ELECTRIC POWER SUPPLY	kVA/V	25/220	25/220	25/220	25/220
CONTROLLER		FANUC Oi-TF Plus				

※ Design and specifications are subject to change without notice.

[] : Option

NC Specification / FANUC

● : STD ○ : Optional X : N/A

Item	Oi-TF+		
	NS 2000A/B	NS 2000AM/BM	
Controlled axis	Controlled axes	X, Z	X, Z, C
	Max simultaneously controlled axes	4	
	Least input increment	0.001mm / 0.0001"	
	Built-in stroke limit	Soft overtravel 1, 2, 3	
	Machine lock	●	
Operation functions	Manual handle feed	X1, X10, X100	
	Dry run	●	
	Single block	●	
	Feed per minute	G94	
	Feed per revolution	G95	
	DNC operation	Ethernet, CF card	
	Thread cutting pause	○	
Interpolation functions	Linear interpolation	G01	
	Circular interpolation	G02, G03	
	Dwell	G04	
	Cylindrical interpolation	G70.1	
	Skip	G31	
	Nano Smoothing	X	
	Polar coordinate interpolation	●	
	Reference position (zero) return	G28	
	Reference position (zero) return check	G27	
	2nd, 3rd, 4th reference point return	G30	
	Variable lead thread cutting	●	
Feed function	Thread repair	Manual guide i (required)	
	Rapid traverse override	F0, 25%, 50%, 100%	
	Feedrate override	0~200%	
	Jog override	●	
	AI look ahead	X	
Spindle function	AI contour control II	OPT(200 block)	
	Spindle orientation	●	
	Rigid tapping	M29	
	Spindle override	S0 ~ 150%	
Tool functions	Arbitrary speed threading	○	
	Tool number command	T4-Digt Tool number	
	Tool nose radius compensation	G40 ~ G42	
	Tool offset pairs	128-pairs	
	Tool geometry / wear offset	●	
	Tool length compensation	●	
	Tool life management	●	
	Tool path graphic display	●	
Program input	Absolute / incremental command	G90/G91	
	Repeating canned cycle	●	
	Repeating canned cycle 2	●	
	Canned cycles	●	
	Drilling canned cycle	●	
	Decimal point input	●	
	Inch / metric conversion	G20 / G21	
	Program restart	●	
	Sub program call	●	
	Max programmable value	±99999.999mm/±9999.9999"	
	M function	3 digit	
	Custom macro	●	
	Addition of custom macro common variables	#100~#199, #500~#999	
	Direct drawing dimension programming	●	
Programmable data input	G10		
Tape code	ISO / EIA		
Optional block skip	●		
Workpiece coordinate system	G52 ~ G59		
Addition of workpiece coordinate system	X		
Interface function	Embedded ethernet	●	
	Fast ethernet	X	
Setting and display	Alarm and operator history display	●	
	Run hour and parts count display	●	
	Loadmeter display	●	
	Self diagnosis function	●	
	Extended part program editing	●	
	Machining condition selection function	○	
	Machining quality level adjustment	X	
Data input/output	Display screen	10.4" color LCD	
	Multi-language display	25 language	
	Fast data server	X	○
Editing operation	RS232C interface	●	
	Memory card input / output	●	
	USB memory input / output	●	
Editing operation	Part program storage size	2Mbyte	
	Number of registered programs	1,000EA	
	Manual guide Oi	○	X
	Manual guide i	○	●